



For a durable surface prime the pine then spray on two coats of gloss acrylic enamel.

STORAGE PROJECT

Mobile island bench

(Project courtesy of Handyman Magazine)

Use radiata pine with dowel joints to build a server

PROJECT DEAN HANNAH MAIN PICTURE SUE FERRIS

DIY > \$370
 HAVE IT DONE FOR \$620
SKILL > 1 2 3 4 5
TIME > 2 DAYS

The ultimate entertainer, this island bench has a shelf plus castors so it can be moved when stacked with food and drinks. Built from radiata pine, the frame and shelf are assembled using 10 x 50mm fluted dowels. The top is cut from 1200 x 600 x 19mm laminated pine, about \$60 from Porta Mouldings (www.porta.com.au).

APPLYING THE FINISH
 Before attaching the hardware use a brush to apply a combined primer and sealer, such as Dulux 1 Step precoat, about \$37 a litre. Finish the trolley with two coats of gloss acrylic enamel using a brush or paint sprayer for a sleek, modern finish. TIP Dulux Aquanamel, about \$39 a litre can be applied using a paintbrush or spraygun such as the Wagner Wallperfect W665. >



Front legs are shorter than the back to accommodate the height of the castors.



Wagner Wallperfect W665 spray gun, \$249. www.wagnerspraytech.com.au

Attaching the hardware



FOR CASTORS make 2mm diameter pilot holes in the front legs then attach 100mm locking castors, about \$43 each, using the supplied screws.

FOR THE RAIL attach a 430mm long bathroom towel rail to the back, positioning it 40mm from the benchtop to use as a handle.

HOW TO Build the mobile bench

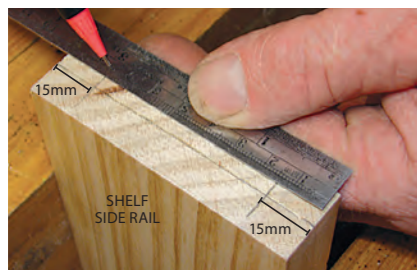

1 Mark the dowels
On the end of the top and shelf rails use a marking gauge to mark the centre then pencil over the groove and mark the dowel holes 15mm from the edges.
TIP Set the marking gauge stock 9.5mm from the pin.



2 Drill the dowel holes
To prevent drilling too deep add a rubber grommet or wrap masking around a 10mm dowel bit 27mm from the tip to drill the dowel holes.
TIP A dowel bit has a point at the centre that prevents it from moving off the mark when drilling.

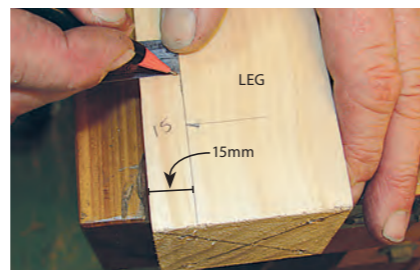

3 Mark up the legs
Use a ruler to mark down the outside faces of the legs to position the rails 15mm from the edge.
TIP The top rails are flush with the top of the legs, and the top of the shelf rails are 460mm from the top of the legs.



4 Mark the dowel positions
On the rails, position 10mm dowel centres in the holes to mark matching holes on the legs, keeping them parallel with the 15mm inset.
Assemble without adhesive to check the fit, labelling the joints for final assembly.



5 Smooth the edges
Use a hand plane to bevel the edges, except the end of the rails, the top of the top rail and top of the legs then sand with 180 grit abrasive paper to round over the edges.



6 Join the end rails and legs
Apply PVA adhesive to the holes in the end rails, hammer in the dowels then join them to the legs and check for square. Clamp, remove excess adhesive with a damp cloth and leave to dry.
TIP Use 5mm dowel offcut to apply PVA.

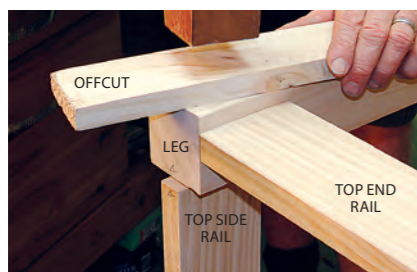

7 Attach the side rails
Apply PVA adhesive to the holes in the side rails, hammer in the dowels then join them to the legs, using a timber offcut to protect the surface from marking. Check for square, clamp, remove excess adhesive and leave to dry.

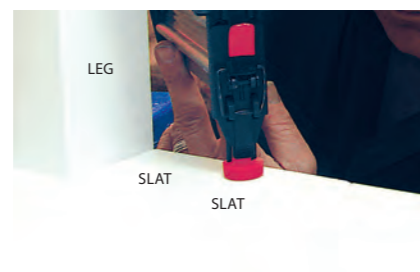

8 Secure the shelf slats
Position the shelf slats over the rails with the outer ones flush to the rails, securing with adhesive and 40mm brads. Position the benchtop and secure using three 38mm angle brackets on the sides and two on the ends using the supplied screws.

Making the top

Join three 1000 x 240 x 19mm pine boards edge to edge with adhesive and dowels spaced 200mm apart then clamp and leave to dry. Use a tablesaw or circular saw to trim the 720mm width to 600mm.



Sash clamps hold the top while the adhesive dries.

KITCHEN TROLLEY (measurements in mm)

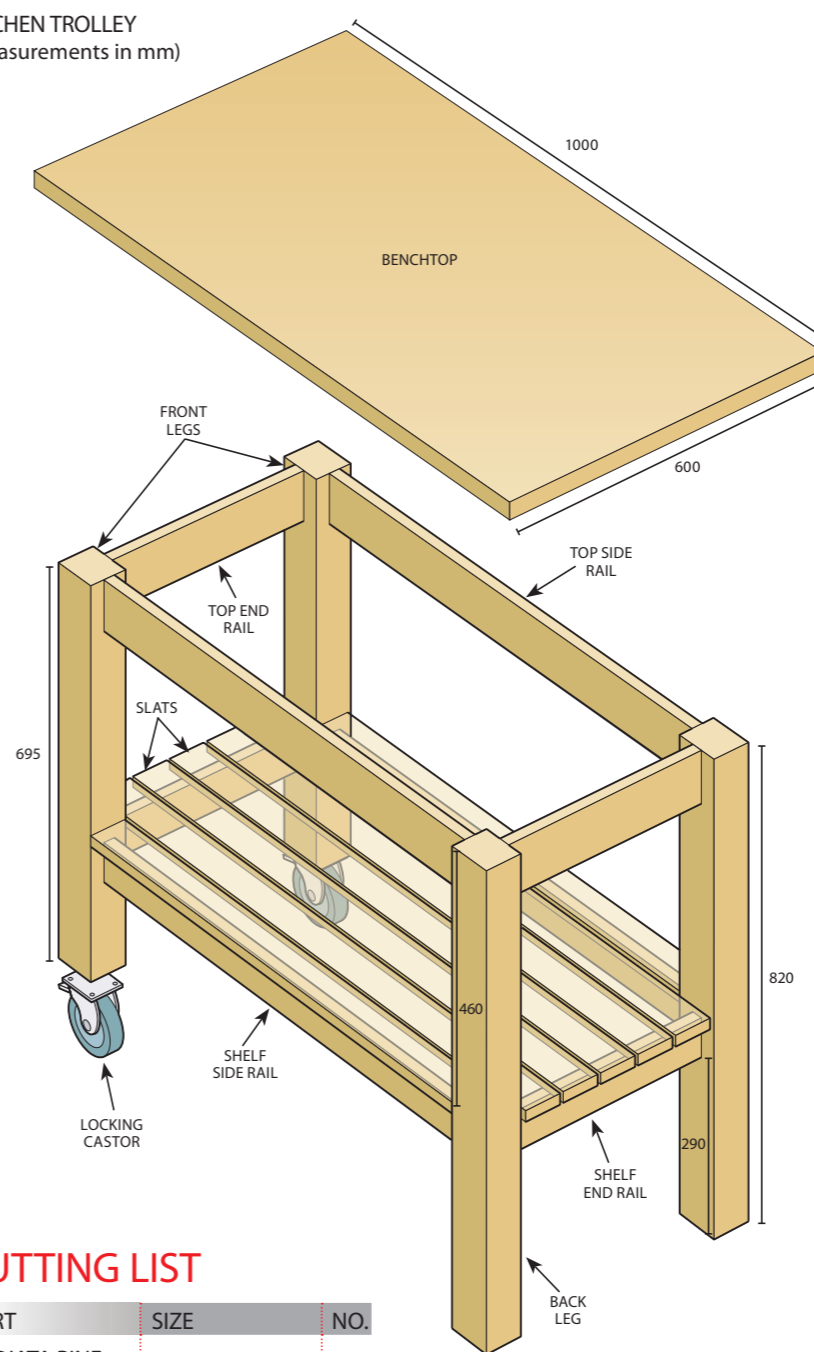

CUTTING LIST

PART	SIZE	NO.
RADIATA PINE		
Benchtop	1000 x 600 x 19	1
Back legs	820 x 70 x 70	2
Front legs	695 x 70 x 70	2
Top side rails	760 x 90 x 19	2
Shelf side rails	760 x 70 x 19	2
Top end rails	360 x 90 x 19	2
Shelf end rails	360 x 70 x 19	2
Shelf slats	760 x 70 x 19	2
	900 x 70 x 19	5